



by ella's bubbles

Representing these Barrier Free, Roll in Shower model numbers:

5050 BF 4P 1.0
Center

4836 BF 4P .875
Center

5430 BF 4P 1.0
Right/Left

6030 BF 5P .75
Center

6030 BF 5P 1.0
Right/Left

6033 BF 5P 1.0
Right/Left

6033 BF 5P .75
Center

6036 BF 5P .875
Center

6036 BF 5P 1.0
Right/Left

6048 BF 5P 1.0
Center

6060 BF 3P 1.25
Center

6060 BF 5P 1.125
Center

3838 BF 4P .5
Center

6232 BF 5P .75
Center

6238 BF 5P .75
Center



ELLA BARRIER FREE ACCESSIBLE SHOWERS
OWNERS MANUAL



Table of Contents

by ella's bubbles

Getting Started: Tools and Materials	1
Planning your Installation	2-3
Framing Diagrams.....	4
Installation Instructions	5-16
Collapsible Dam Instructions	17-19
Warranty Information	20
Warranty Activation Form	21-22

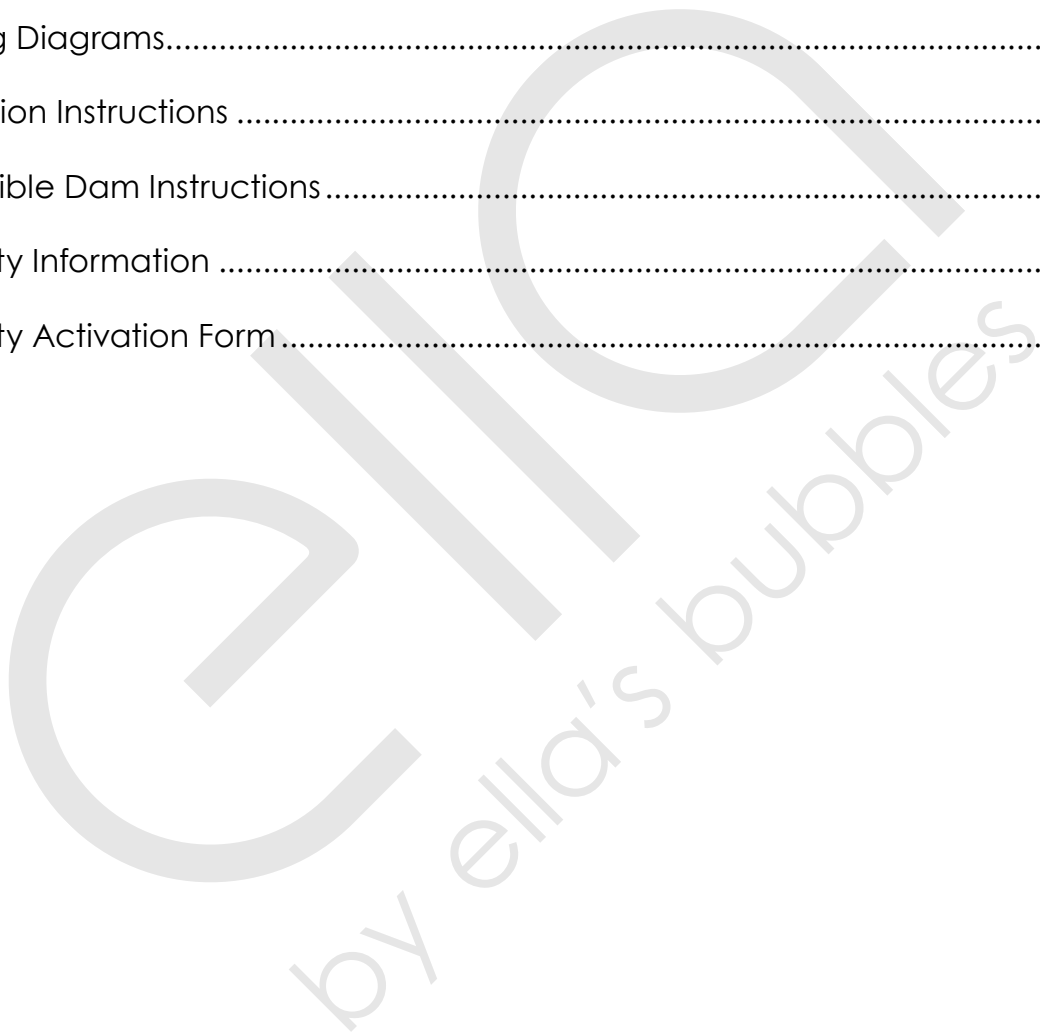



by ella's bubbles

Getting Started: Tools/Materials

Tools/Materials you might need for proper installation

- hammer
- drill with Phillips screw bit
- 1/2" notched trowel
- spatula
- grease pencil (china marker)
- Auger mixing tool for drill
- caulking gun
- 4' level
- 2' level
- nails
- (50+) 1 1/4" wood screws
- solid wood flooring adhesive - (2) one gallon buckets per shower or 100% silicone adhesive
- (2) gallons of water - for mixing bedding compound and water test around drain
- tube of white bathroom caulking
- (2) tubes of 100% clear silicone caulking
- (3) 8' 2x4s
- (1) 8" long 2x4
- (1) 24" long 2x4
- (2) large wiping cloths
- self-caulking shower drain fitting



by ella's bubbles

Planning your Installation

For best results, please read and follow all directions carefully.

1. Avoid exposure to weather. Product carton is not waterproof. Carton exposed to rain or snow may result in accumulated water penetrating the back laminates of the shower pan and soak the glassed in reinforcement supports causing bulges in the gel coat surface.
2. Most handling damage is the result of impact blows to the back of the fiberglass units.
3. Never drag this fiberglass product on any surface. Always carry the pan or use a two wheel dolly.
4. Never drop the fiberglass shower pan from any height, not even an inch or stress cracks are likely to occur.
5. Placing objects inside the unit can cause scratches or nicks to the finished surface. Do not use the shower pan as a trash receptacle! Always place a drop cloth or cardboard on the floor when working inside the shower.
6. Never clean fiberglass gel coat surface with metal tools of any kind, including razor blades.

BRIEF OVERVIEW

NOTE: *Unit will not install properly if framing pocket is not square and of proper size. The dimensions shown in the FRAMING DIAGRAMS are 1/4" larger than the size of the shower. This product is manufactured to tight specifications. The 1/4" over sizing is for maneuvering and installation ease. If 1/4" over is not reasonable, sizing closer to the product actual dimensions is allowable. When trial fitting the shower, use a level to confirm the parts are level and plumb. If any gaps are present between the shower and framing, use furring strips to fill the gaps. If the walls and floor are not level, there may be an excessive gap at the seams. The unit is designed to allow an 1/8" gap at the seams.*

1. Review the Framing Diagrams in Figure 1. Modify existing framing if required. For new construction, build framing structure in accordance with product dimensions and notes shown in the Framing Diagrams. The two wall Framing Diagram is for the 6060 3P two wall shower only.
2. The shower base will be installed, leveled, and fastened to the framing before the walls are installed. It is essential the framing pocket be square and plumb for the unit to install properly. The floor also must have no voids or out of level conditions. If these are present, they must be corrected before installation. Floor leveling compound can be purchased at a local home improvement store. Make sure the area is completely dry.



by ella's bubbles

Planning your Installation Continued

3. Following the shower pan installation, place the back wall sections, then the side walls. The parts are indexed to one another by a slot and pin connection system. The parts are pushed tight together before connection to the framing pocket is made. To have a successful installation, two persons are required.

4. Plan for the location of the shower water control valve.

NOTE: *If planning to install the control valve in the back wall of the shower with a two piece back wall, consider the location of the seam in the wall. The control valve must be located at a height where the seam and mounting flange do not cause a conflict with placement of the control valve, or water supply lines. These considerations are not necessary if installing on the one piece back wall, or side wall. Plan for routing the water supply lines to the control valve installation location.*

5. In the installation location, the drain opening in the floor should have a 6" core for the drain pipe, and a 10" x 10" x 1/2" deep recess in the sub floor. (The drain core must be blocked when filled with Thin-Set). The 10" x 10" x 1/2" deep recess is required to assure proper drainage. See Detail of Drain Core Area

6. Check the outside of the package for visible shipping damage. If damage is noted, contact your supplier before proceeding with the installation.

7. Locate accessories if any were ordered. They will be packaged in the pan box. Remove those and store them in a safe location for easy retrieval.

8. Identify each package and its contents. The label on the box is clearly marked indicating a shower pan and wall panels.

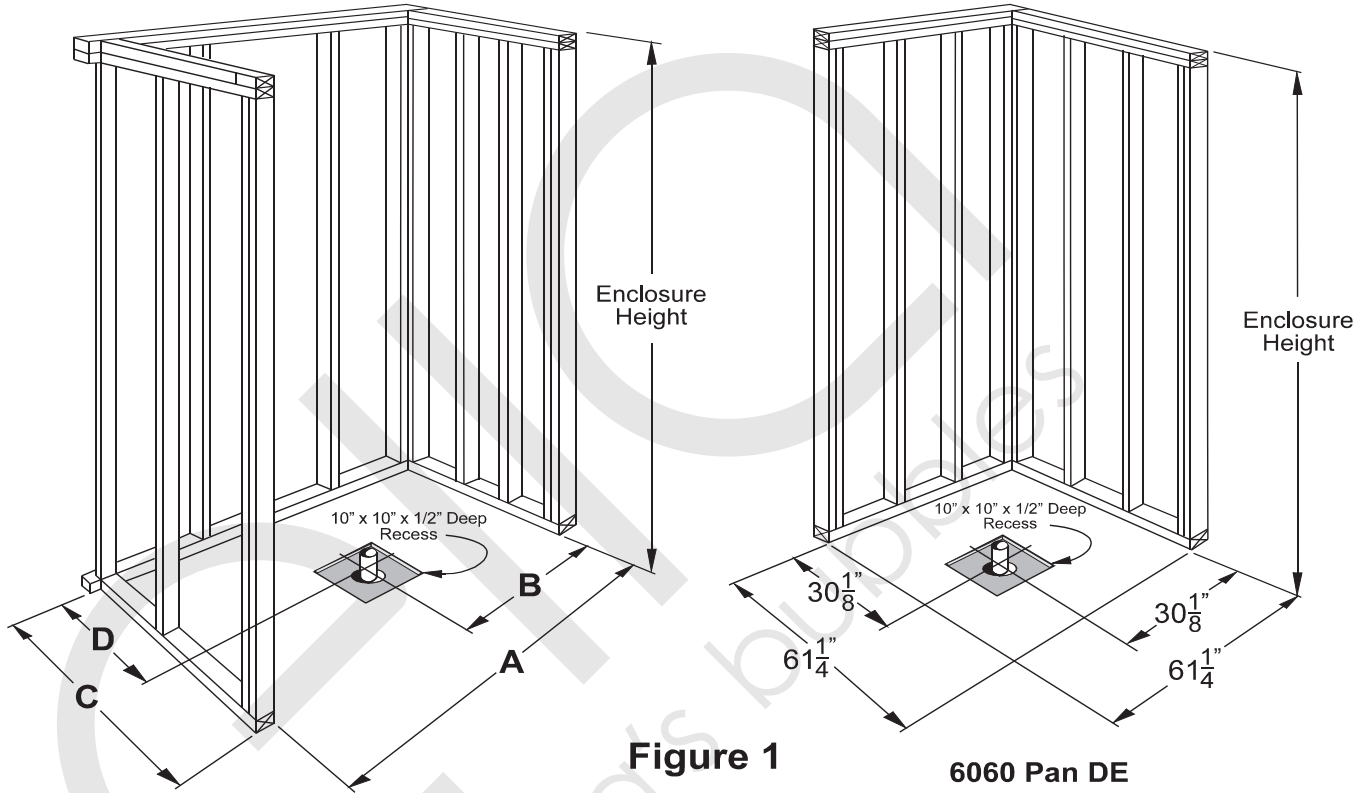

Figure 1

6060 Pan DE
Double Entry Pan

	A	B	C	D
3838	38 7/8"	19 7/16"	38 5/8"	19 1/8"
4836	48 1/4"	24 1/8"	37 1/4"	18 1/8"
6030 C	60 1/4"	30 1/8"	31 1/4"	15 1/8"
6030 L-R	60 1/4"	8 9/16"	31 1/4"	15 1/8"
6033 C	60 1/4"	30 1/8"	33 5/8"	15 1/8"
6033 L-R	60 1/4"	8 9/16"	33 5/8"	15 3/8"
6036 C	60 1/4"	30 1/8"	37 1/4"	18 1/8"
6036 L-R	60 1/4"	8 9/16"	37 1/8"	18 3/4"
6048	60 1/4"	30 1/8"	49 1/4"	24 1/8"
6060	60 1/4"	30 1/8"	61 1/4"	30 1/8"
6232	62 5/8"	31 5/16"	32 1/2"	16 3/8"
6238	62 5/8"	62 5/8"	38 1/2"	19 3/8"
5050	50 1/4"	25 1/8"	50 1/8"	25"

DETAIL OF DRAIN CORE AREA

6" Diameter Drain Core
10" x 10" x 1/2" Deep
Recess Around Core

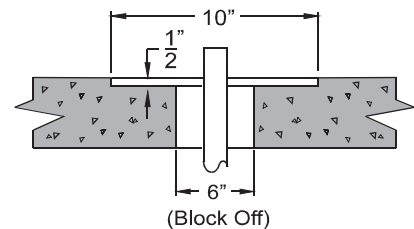

1. Prepare the installation area by sweeping the area completely clean.

2. Framing pocket must be sized according to the information provided in the Framing Diagram. It is recommended that the front studs at each side be doubled for added strength. Framing must be extremely square and plumb in order to accomplish a successful installation.

3. Install hot and cold water supply lines with the control valve. Mount to the framing.

4. It is extremely important that the floor area intended for the installation be flat and level. Any areas over 1/8" out-of-level will prevent the installation from being successful. If an area out more than 1/8" is found, float the floor area with a floor leveling compound. This material must be placed and cured (dry) before proceeding with the shower installation.

5. **A special note:** During handling and transport, the product may be slightly bent. It is very important that the seam side of each wall, and the threshold of the pan does not have any bow or bend. This product is engineered with materials that allow for the sections to be pressed back to the normal and straight factory form that is intended.

As each section is removed from the packaging, use a straight edge to check the straightness of the wall sections and of the threshold. An example of checking the threshold is illustrated in Figure 2A. Check all the parts, and if not straight, follow the procedures outlined below to bring the parts back into the intended condition.

In the event they are not straight to 1/16", pressure can be applied to the top side of the material. This can be accomplished by placing blocks under the two extreme corners.

Always place a soft rag on the finished surface where it contacts the wood blocks, and under your feet to avoid damaging the finish.

Gently step on this area and allow your body weight (Up to 250 pounds), to flex the material back straight. Confirm straightness, repeat if necessary until +/- 1/16" is accomplished. Figures 2B and 2C

A complete dry fit for the shower base and walls is recommended. A dry fit in this instance is defined as securing the sections to the studs with no silicone and minimal screws to confirm a good fit, and the framing accommodates the sections. To achieve a dry fit installation, proceed with steps 6 through 23 without using the silicone, floor adhesive and minimal screws to secure to the framework.

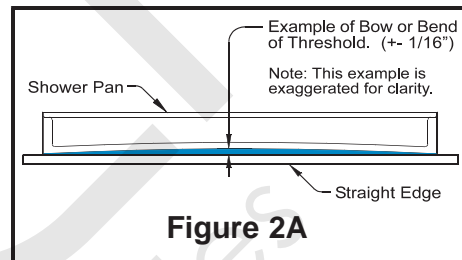

Figure 2A

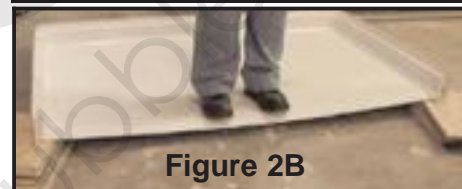

Figure 2B

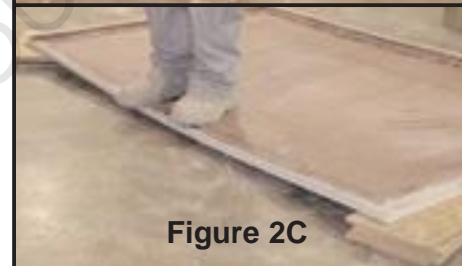

Figure 2C



Figure 3



Figure 4

Once the dry fit has been done and the fit confirmed, disassemble the components. Resume step 5 and follow each step carefully.

6. Carefully measure the framing pocket to assure it is of proper size for the unit to be installed. Refer to dimensional information in the Framing Diagrams in Figure 1.

7. Check the framing pocket for square. Check to assure the vertical studs are plumb. To have tight seams where the parts meet, it is very important that the framing pocket be exceptionally square and plumb.

Check for square by holding a measuring tape from the back left corner to the front right corner, as shown in Figure 4. Repeat for the other side. If both dimensions are the same, the framing is square. Adjust if necessary.

8. The next step is to dry fit the shower pan to the studs and confirm the drain location.

The better fit of the pan, the better all wall parts will assemble as intended with minimal gaps at the seams.

NOTE: In Figure 5 the two installers have placed the shower pan on the floor, and are pushing it into the installed position. One of the installers is using a short piece of 2 x 4 wood to hold the front of the shower pan off the floor. This will assist in moving the pan into the installed position while preventing chipping the front edge if it were to slide along the sub floor.

After the pan is set, fill any gaps between the mounting flange and the framing with wood shims or furring strips to achieve solid contact. The flange must be in contact with the studs along all sides. The back corners of the shower pan should be in contact with the framing, as seen in Figure 7. Shim these areas if required.

9. Once the shower pan is put into place and fit is confirmed, draw a pencil line on the sub floor indicating the front point of the threshold of the pan. See Figure 8

Place a piece of cardboard in the floor of the shower to protect the floor during the additional steps of installation. There is a cut out for this on the pan box.



Figure 5



Figure 6



Figure 7



Figure 8

10. Confirm the pan is level by using a long level on top of the threshold, and along the sides and back.

NOTE: The level is used on the same horizontal surface that has the pins. This will be important to allow the wall panels to fit correctly. See Figures 9A and 9B

If the pan is not level, shim the appropriate areas to achieve level. Do not shim more than 1/8". If shimming over 1/8" is required, remove the pan and correct the sub-floor area by "floating" a floor leveling compound.

11. Drill holes through the mounting flanges into each framing stud. These holes should be drilled using a 1/8" drill bit. See Figure 10

NOTE: Plan on using flat or pan head screws to secure the shower pan. An 1/8" gap is provided in the shower design to account for the screw heads. This gap will allow clearance so the walls may be assembled to the shower pan.

12. The next step is to permanently install the shower pan. A helpful tip to make this easier is to rotate the pan upward and lean against the back framing studs of the pocket. This will remove the pan from the work zone without removing it from the stud pocket. Do not secure the pan to the studs at this point because you may need to reach around the pan as you install the drain fitting detailed in the next step. Make sure pan is angled enough so it will not fall.

13. Install the drain fitting on the shower pan. Apply a bead of 100% silicone caulking around the recessed molded drain area on the finished side of the pan. Remove the nut and all gaskets from the drain body. Slip the threaded shank of the drain body through the hole. Follow the instructions provided with the drain fitting to install the gaskets in the proper location. When all gaskets and locknut are in place on the bottom side of the shower, tighten the nut to secure the shower drain assembly. From the top side of the drain assembly, remove the rubber caulking gasket located on the inside of the drain fitting. This will allow the drain pipe to slip through the drain fitting on the shower.

A diagram of a typical drain assembly is shown in this manual.

Wipe away any excess caulking that may have squeezed out on the inside of the pan.

Now secure the pan in the upright position to the back framing. Use a piece of scrap 2 x 4 lumber to temporarily secure it. See the example in Figure 12.



Figure 9A



Figure 9B



Figure 10



Figure 11

14. A solid wood floor adhesive or 100% silicone adhesive will be used to "glue" the bottom side of the shower pan to the sub floor. The following steps will detail the appropriate steps to accomplish this.

15. Clean the sub-floor thoroughly, wiping away all loose debris. Wipe up any moisture. Never use adhesive on a dirty or damp surface.

16. To secure the shower pan to the floor a solid wood floor adhesive must be applied to the entire sub floor area where the shower pan will rest, 3/8" thick and 3" apart.

Using a 1/2" notched trowel, apply adhesive evenly over the pan contact area. Bring the adhesive up to the threshold pencil mark and also make sure the adhesive will be in contact with the back side of the pan. The long edge of the trowel may be needed to get the adhesive to the far back of the contact area where the pan is resting against the framing studs in a vertical position. (Pan not shown in Figures 13 A and B).

After the adhesive is troweled over the sub floor, use a spatula to wipe the adhesive over the entire area where the pan will sit. The exception will be the drain box area. This area will be filled with thin-set non shrink mortar. Do not fill this area above the floor line and do not spill any of this thin-set material onto the contact adhesive. See Figure 13B

Non shrink thin-set mortar can be purchased at any local home improvement store. Please follow the mixing directions on the bag.

In this step, apply the adhesive to the flat floor area and fill the boxed area around the drain pipe with the Thin-Set mortar.

17. After the adhesive and thin-set materials are in place, rotate the pan back into place for installation.

(Hint) In order to reach the pan without stepping on the adhesive, place a short piece of wood over the drain area. Use this to step on to remove the 2 x 4 that is holding the pan against the back framing. See Figure 15

NOTE: The working life of the flooring adhesive is roughly one hour. (Refer to the label on the adhesive for actual working time). After step 16 is complete, the entire installation process through step 23 must continue. If for any reason the installation cannot be completed within the working time of the adhesive, after step 16, jump ahead to step 23.



Figure 12

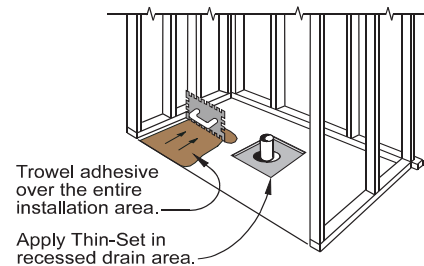

Figure 13A

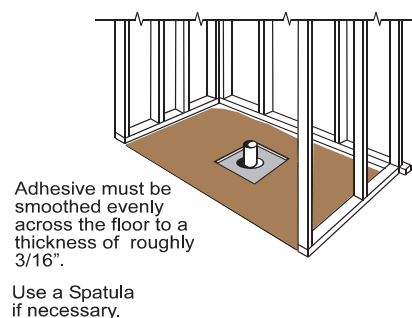

Figure 13B

Rotate the pan back to the horizontal position. As you lower the pan to the sub floor, align the drain pipe with the drain fitting, and with the pencil mark at the front of the threshold.

When the pan is seated into the adhesive, place the cardboard on the shower floor for protection. Thoroughly walk around in the shower. This will assist in seating the pan into the adhesive.

Attach the pan to the studs by installing the flat top/pan head screws through the holes drilled into the flange. Snug the screws up tight so the screw heads will be clear of the side wall panels for assembly. Use care not to over tighten to the point that causes flange breakage.

18. Before installing the walls, confirm the ledges where the walls sit are level. Check with a long level as shown in Figure 16. If there is an out of level condition, remove screws and adjust as required.

19. Before the adhesive cures, confirm the floor slope to the drain has been maintained. To do this, use a 2 foot level at various points around the drain to the adjacent wall to check for draft. Make sure there is a downward slope to the drain in all directions around the drain. Visually inspect the floor to be sure there are no humps or dips that could cause improper drainage. See Figure 17A and 17B.

20. The next step will be to place the wall panels on the pan. The back wall will be installed first. If the water control valve is in the back wall, carefully measure and mark the location on the surface of the wall panel. If installing in a shower with a two piece back wall, the valve probably will be installed through the lower wall panel. Make certain the valve does not conflict with the mounting flange or seam. Read the installation instructions provided by the valve manufacturer. Before the Trial fit, carefully drill the valve hole (s) in the panel. When drilled, dry Trial fit the back wall panel (s) on the shower pan to test the fit.

Confirm the gap where the wall seats to the pan is 1/8" or less. Make sure the seam for the two piece wall is also 1/8" or less. Adjust the valve hole size and location if required.

Lift the wall panel with the valve hole away. Complete the valve installation and connection to hot and cold water supply at this time. Also complete shower supply connection. Strap pipes to framing if required. This is the last access to the plumbing before the wall is permanently installed.



Figure 15



Figure 16

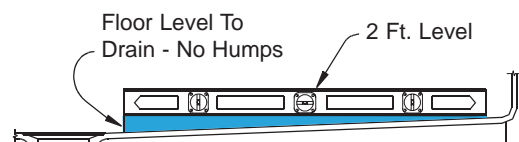
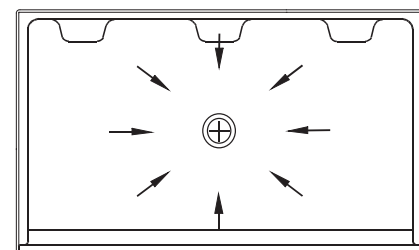

Figure 17A



Level in all directions around the drain to assure good drainage.

Figure 17B

21. If all fits are good, proceed with the installation of the back wall. The installation procedures described in this step apply for installation of one or two piece back walls.

Wipe clean the ledges on top of the pan. Apply a continuous bead of 100% RTV silicone caulking along the back ledge of the pan where the back wall will sit. The bead should be placed at the middle of the ledge, and be 3/8" wide. The bead should go completely around each alignment pin.

There are slots on the underside of the wall. There are alignment pins in the pan that will insert into the slots on the bottom of the wall. See the detail in Figure 19.

The lower section of the back wall is the panel with a single, molded soap dish. Lift this panel up and carefully lower it onto the back ledge on the pan.

Push the wall panel down to seat it in the caulking. Check the fit for level and plumb.

Note to installer: *There is a difference having the bubble between the lines and a plumb wall. The wall must be VERY plumb or a gap larger than 1/8" will be present where the side walls mate the back wall. Use wood shims or furring strips to fill any space between the back wall flange and the studs.*

Align the wall section where it meets the shower pan so it is centered on the pan, and install wood shims or furring strips if necessary.

Pre-drill the mounting flanges. Attach the wall with screws through the back wall flange into the framing. Be sure the wall panel remain level and plumb. (For the 4836 4 piece, this step will apply for the entire back wall as one piece).

22. For five piece units, the next step is to place the top section of the back wall. Clean the back ledge and apply a continuous bead of 100% RTV silicone caulking along the ledge of the back wall where the top part of the wall will sit. The bead should be 3/8 wide and placed at the middle of the ledge. It should go completely around each alignment pin.

Lift the top back wall panel and set it on top of the lower wall. Press the panel down to seat in the caulking. The top and bottom wall panels must be level and plumb. Shim if necessary. The seam between the panels should be no more than 1/8".



by ella's bubbles

Pre-drill holes and attach with screws along the top back flange into the framing studs. Make sure the two wall panels are in alignment and are level and plumb. Place level or straight edge on both vertical flange where the wall will mate to the back wall and check to assure there are no gaps. (For the 4836 four piece which has a single piece back wall panel, skip this step).

23. If the water control valve is located on one of the side walls, it is important to dry trial fit that panel first. Carefully measure and mark the location of the valve on the surface of the side wall. Read the installation instructions provided by the valve manufacturer. Carefully drill the valve hole(s).

Trial fit the side wall panel to the shower pan. Wipe clean the side ledge. This next step is a two person job.

Lift the side wall panel and set it on the ledge. Set the panel so it is within one inch of the vertical back wall seam. Make sure the pins in the pan index with the slots on the bottom of the wall. Clear your fingers and slide the wall panel toward the back wall. Make sure the alignment pins in the back wall index into the holes on the side wall. See Figure 24

When seated, the seam should have a minimal gap of 1/8" or less. If not, push the end of the side panel until the vertical seam closes. See Figure 25 When in place, check the fit of the valve hole. Adjust size and location if required.

When the fit is good, lift the wall panel away. Complete the valve installation and connection to hot and cold water supply at this time. Also complete shower supply connection. Strap pipes to framing if required. This is the last access to the plumbing before the wall is permanently installed.

Clean the side ledge and apply a continuous 3/8" bead of 100% RTV silicone caulking along the entire length of the mating ledge of the shower pan. Apply the caulk completely around each alignment pin.

Clean and apply a continuous 3/8" bead of 100% RTV silicone caulk along the entire length of the vertical surface of the back wall where the side wall panel mates to the back wall. Apply the caulk completely around each alignment pin. See Figure 23

Lift the side wall and place it on the pan. Make sure alignment pins on the pan and back wall line up. Clear fingers and slide the wall into the installed position. See Figure 25

Confirm fit and level. Inspect that the grout lines on the side wall match up with the grout lines on the back wall.

Using a grease pencil or china marker to make a short line across the grout lines makes it easier to see if the grout lines are in alignment.

Pre-drill mounting flanges and attach to framing studs with screws. Make sure wall panel remains level and plumb and the seam is tight.

Repeat the procedures in Step 22 for opposite side wall.

24. Now that all wall panels are installed, remove the protective cardboard from the floor and use a 2 foot level to re-check the downward floor draft to the drain. Use the same procedure as described in Step 18 of this manual.

25. Install the rubber caulking gasket around the drain pipe. Trim the length of the pipe if necessary. Apply soap to the caulking gasket to lubricate it. Place the caulking gasket on the drain pipe and press it down into the drain assembly until it seats. Snap the strainer plate onto the drain.

Pour water across the floor to confirm good draft to the drain so the water drains completely with no puddling. Make certain the drain does not leak.

NOTE: The manufacturer and supplier of this product is not responsible for leaking drain conditions. Proper installation of the drain fitting and pipe is the installers responsibility.

Since there is minimal floor slope to the drain, it is critical factory slope be maintained so the shower drains well. To accomplish this, temporary bracing must be put in place to assure the floor remains in the proper position as the adhesive cures.

Before installing the bracing, place a padded piece of wood on the top center of the threshold and directly on top of the drain. Pad the wood with soft cloth or cardboard to prevent damage to the finish.

Install temporary 2 x 4 stud bracing so they sit on top of these wood pieces. Attach these studs to the room framing above the shower, or pad to the ceiling. See Figure 26

26. Remove the temporary bracing after 72 hours. Place a piece of cardboard in the shower to protect the finish. Caulk all seams with white acrylic bathtub caulk.

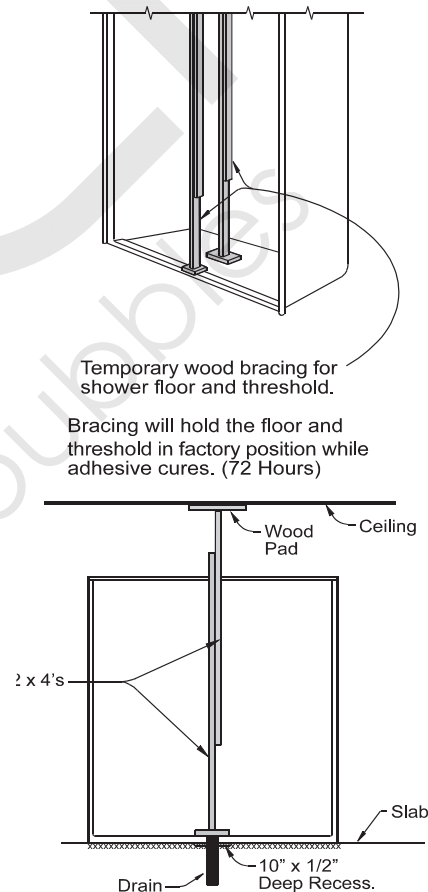

Figure 26

SEAM CAULKING INSTRUCTIONS

Materials and tools required:

- acrylic latex caulk
- wiping cloths/rags
- clean water
- caulking gun
- cup

1. Cut off tip of caulk tube diagonally with opening no larger than 1/8". Figure 27

1. Cut off tip of caulk tube diagonally with opening no larger than 1/8". Figure 27
2. Run a continuous bead of caulk at the seam between the two parts. Figure 28
3. Smooth caulk gently with a wet fingertip. Figure 29
4. Using a clean rag, wipe off excess water and caulk. Figure 30



Figure 27

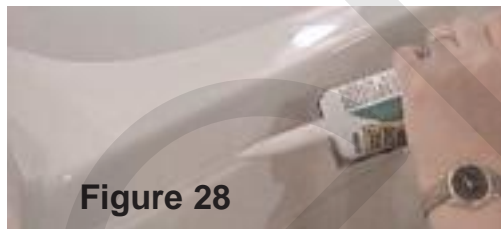

Figure 28



Figure 29



Figure 30

INSTALLATION INSTRUCTIONS FOR SHOWER SEATS WITH SWING DOWN LEGS

(This style seat has four (4) adjustable height legs)

Your seat with swing down legs is fully assembled. Remove it from the box and proceed as follows:

1. Choose the height of the seat you want. Barrier Free style showers will typically have fold up seat installed at 17" to 19" height.
2. After selecting the height you desire, adjust each of the four legs to that height while maintaining the seat in a level position. Lock each of the lock nuts.

3. Place the seat against the wall of the shower where you want the seat to be located. Seat may be centered on the wall for a Barrier Free installation.
4. With the seat placed against the mounting wall, position the two hinges to the wall. Using a pencil, mark the three (3) holes in the flange onto the wall for each hinge. Remove seat from wall.
5. Using a power drill with a 0.120" diameter drill through the wall the three (3) mounting holes for each flange.
6. Apply silicone caulking around and inside each drilled hole before installing the seat.
7. Place the seat against the mounting wall with each hinge aligned to the mounting holes. Utilizing the six (6) #10 x 2" Stainless Steel screws, place a Phillips screw driver into your power drill and securely tighten each of the six (6) screws.

THIS COMPLETES THE INSTALLATION OF THE SEAT

INSTALLATION INSTRUCTIONS FOR GRAB BARS

Recommended tools for installation:

- 1/4" Power Drill
- 1/8" drill bit when drilling through fiberglass
- #2 Phillips Screw Driver and/or Phillips drill insert
- 1/2" Open end wrench or a small Crescent wrench
- Tape measure
- Pencil/pen
- Center Punch
- Silicone Caulk

1. As indicated earlier in this manual, wood reinforcements must be solidly installed behind the tile wall surface to provide a secure mounting surface to attach the grab bars. Grab bars must be installed at these locations only.

2. Select the particular size and style of grab bar you want to install. Certain grab bars have snap in place flange covers, and others have exposed flanges.
3. For grab bars with snap in place flange covers, use the handle of a Phillips screw driver to tap back the covers on the bottom edge of the covers. It will be convenient in the installation process if the covers are tapped together in the center of the grab bar.



by ella's bubbles

4. Determine the position you want the to install the bar. Place the bar against the wall. Using a pencil, mark the location of each mounting hole at both ends of the bar.
5. Using a power drill with a 1/4" diameter carbide tipped drill bit, drill, each mounting hole.
6. Apply silicone caulking around and inside each drilled hole before installing the grab bar.
7. Take two (2) of the #10 x 2" Stainless Steel screws. By hand, start one mounting screw in each end of the bar into the wall.
8. Use a power drill with a Phillips drill bit to fully install these mounting screws.
9. Take the remaining #10 x 2" screws and place them into the remaining open holes. Use care to snug up the screws, but to not over-torque that the screws strip out the factory installed backer board.
10. If installing a bar with snap-on covers, move the covers into place at each flange. Twist the covers clockwise or counter clockwise to tighten the covers onto the flanges.

THIS COMPLETES THE INSTALLATION OF THE GRAB BAR

INSTALLATION INSTRUCTIONS FOR COLLAPSIBLE WATER RETAINERS

Important considerations before you begin: Most manufactured units are designed with a radius where the floor transitions or meets the wall. This is to ensure proper structural strength where the wall meets the floor. The installation of end caps is highly recommended on radius models for proper fit and finish. The caps will also help to keep your curtain inside the water barrier. A properly sized curtain with heavy tape weights combined with a water retainer is the most complete and effective system available today.

Installation of radius models: (For Finished End Cap Installation) Make sure you have ordered the correct length. See chart below. The water retainer strip is designed to travel along the floor to the wall radius until vertical, then capped. (Less Cap Installation) Cut the retainer strip to the shape of the radius where the wall and the floor meet, then caulk. Caps are not required in applications where a 90-degree corner is standard.

Size Verification Chart for all Factory Manufactured Shower Units

For most Acrylic Showers:

- | | |
|--|--------------|
| • 36" ADA barrier free (36" I.D. opening) | 42CWR-White |
| • 48" barrier free (45-46" I.D opening) | 52CWR-White |
| • 60" ADA barrier free shower (60" I.D. opening) | 66CWR-White |
| • Finished End Cap | CWRCAP-White |

NOTE: 1 1/2" wide flat mounting surface required.



by ella's bubbles

Identifying proper mounting location: It will be helpful to determine whether your Gel-coat or Acrylic reinforced shower unit model has a small molded ridge or "water runoff assist" or trench design on your unit. You will find this feature on the floor of approximately 1-3 inches from the front entry edge of your shower unit. The inside edge of the water retainer should rest on the crown of the ridge allowing the water to run off properly. Use this ridge as your guide to mounting the retainer parallel with the water run off ridge.

Models less the ridge: All name brand barrier free showers that may not have a water run off ridge or recessed trench and applications such as tile, marble or cement floor surfaces, purchaser must determine the proper mounting location and length. Helpful hint: determine by desired location of curtain or directly below curtain rod.

Tools & Materials required: Utility Knife, Tape measure, Straight edge, Clear or White 100% Silicone Adhesive caulk, Blue Masking tape, Rubbing Alcohol, bucket of water and clean rags.

INSTALLATION STEPS WITH FINISHED END CAPS

1. Thoroughly clean threshold surface of all soap scum and debris using standard bath cleanser. Chemically clean surface with rubbing alcohol.
2. Verify the required length anticipating the vertical rise, making certain there is enough retainer strip to make a vertical rise on the end walls.
3. Determine and mark center point of shower.
4. Determine and mark center point of water retainer strip.
5. Turn over water retainer strip and make cut on orange peel off strip at half way mark. Peel off a portion (approx. 4") of the orange peel off strip in one direction exposing the adhesive.
6. Align strip with pre-determined pencil mark or molded ridge crown of shower unit starting at the half way mark. Press on and adhere approximately 4" of strip. Pull and stretch to wall and align before removing remainder of orange peel off strip. Press into place.
7. Peel, stretch, alien and pull remaining half to wall. Press into place.
8. Push in the male end of your end cap into the water retainer. Adhere end cap to unit with adhesive caulk and wipe clean. White or clear adhesive type caulk is recommended.
9. Use masking tape to temporarily hold cap in place until adhesive cures.
10. Optional: The outer edges beneath the retainer may be caulked if desired to prevent soap and shower debris from lodging beneath the retainer. The adhesive tape does not extend to the edge (by design) to allow the retainer to absorb the impact energy of a rolling shower chair in high use applications. Wipe off excess caulk and let cure (according to caulk specifications) prior to shower use.

STEPS LESS FINISHED END CAPS

1. Thoroughly clean threshold surface of all soap scum and debris using standard bath cleanser. Chemically clean surface with rubbing alcohol or equal.
2. Verify the required length anticipating the radius shaping required on each end of the strip.
3. Determine the shape of the end cut required for proper fit and finishing.
4. Begin at one end only.
5. Create template of wall shape (if necessary) with cardboard or material of choice.
6. Trace shape onto retainer, cut and trim with utility knife.
7. Beginning on the shaped end, peel back a small 4" section of the orange peel off strip.
8. Align strip with pre-determined pencil mark or molded ridge crown of unit. Press on and adhere the 4" section of exposed strip into place.
9. Before removing remainder of orange peel off strip, stretch retainer to opposite wall, mark and template for proper location proceeding final cut.
10. Remove remaining orange peel off strip and stretch retainer to its final position. Press and adhere into place.
11. Caulk end cuts and wipe clean. A silicone adhesive caulk is recommended.
12. Optional: The outer edges beneath the retainer may be caulked if desired to prevent soap and shower debris from lodging beneath the retainer. The adhesive tape does not extend to the edge by design to allow the retainer to absorb the impact energy of a rolling shower chair in high use applications. Wipe off excess caulk and let cure (according to caulk specifications) prior to shower use.

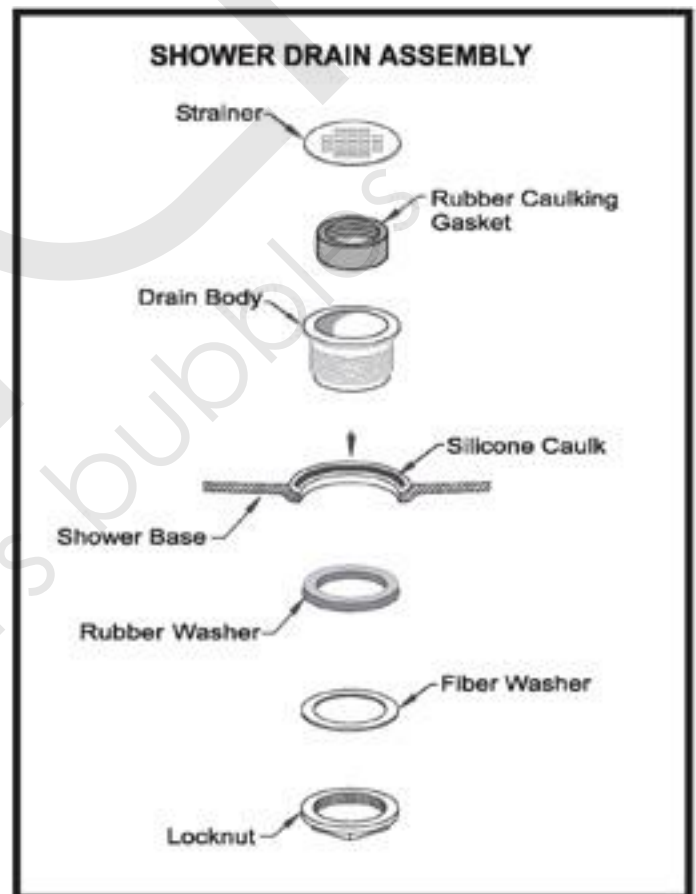



Collapsible Dam

by ella's bubbles

Tools you might need for proper installation

- Utility knife
- Tape measure
- Straight edge
- Clear or white silicone adhesive caulk
- Masking tape
- Rubbing alcohol
- Bucket of water
- Clean rags

Thank you for purchasing Praxis Bath-ware. For best results, please read and follow all directions carefully.

FOR MODULAR SHOWERS WITH RADIUS CORNERS

Fits all fiberglass reinforced models including: Acrylic, Gel coat, Vikrel, Solid Surface, Composite, Cultured Marble

Important considerations before you begin:

Most manufactured units are designed with a radius where the floor transitions or meets the wall. This is to ensure proper structural strength where the wall meets the floor. The installation of end caps is highly recommended on radius models for proper fit and finish. The caps will also help to keep your curtain inside the water barrier. A properly sized curtain with heavy tape weights combined with a water retainer is the most complete and effective system available today.

ORDER THE CORRECT LENGTH

Make sure you have ordered the correct length. See chart below. The water retainer strip is designed to travel along the floor to the wall radius until vertical, then capped.

SIZE VERIFICATION CHART FOR ALL FACTORY MANUFACTURED SHOWER UNITS

SIZE MODEL/PART NUMBER

36" ADA barrier free (36" I.D. opening)

42CWR-White

48" barrier free (45-46" I.D opening)

54CWR-White

60" ADA barrier free shower (60" I.D. opening)

66CWR-White

Finished Radius End Caps (pair required)

EX1613-White

NOTE: 1 1/2" wide flat mounting surface required.

Identifying proper mounting location: It will be helpful to determine whether your fiberglass reinforced shower unit has a small molded ridge or "water runoff assist" design on your unit. You will find this feature on the floor of approximately 1-3 inches from the front entry edge of your shower unit. The inside edge of the water retainer should rest on the crown of the ridge allowing the water to run off properly. Use this ridge as your guide to mounting the retainer parallel with the water run-off ridge.

Models less the water run-off design ridge: All name brand barrier free showers that may not have water run-off a ridge and applications such as tile, marble or cement floor surfaces, purchaser must determine the proper mounting location and length.

INSTALLATION INSTRUCTIONS WITH FINISHED RADIUS END CAPS

1. Thoroughly clean threshold surface of all soap scum and debris using standard bath cleanser. Chemically clean surface with rubbing alcohol.
2. Verify the required length anticipating the vertical rise, making certain there is enough retainer strip to make a vertical rise on the end walls.
3. Determine and mark center point of shower.
4. Determine and mark center point of water retainer strip.
5. Turn over water retainer strip and make cut on orange peel off strip at half way mark. Peel off a portion (approx. 4") of the orange peel off strip in one direction exposing the adhesive.
6. Align strip with pre-determined pencil mark or molded ridge crown of shower unit starting at the half way mark. Press on and adhere approximately 4" of strip. Pull and stretch to wall and align before removing remainder of orange peel off strip. Press into place.



Collapsible Dam Continued

by ella's bubbles

7. Peel, stretch, alien and pull remaining half to wall. Press into place.

8. Push in the male end of your end cap into the water retainer. Adhere end cap to unit with adhesive caulk and wipe clean. White or clear adhesive type caulk is recommended.

9. Use masking tape to temporarily hold cap in place until adhesive cures.

10. Optional: The outer edges beneath the retainer may be caulked if desired to prevent soap and shower debris from lodging beneath the retainer. The adhesive tape does not extend to the edge (by design) to allow the retainer to absorb the impact energy of a rolling shower chair in high use applications. Wipe off excess caulk and let cure (according to caulk specifications) prior to shower use.

FOR TILE SHOWERS OR MANUFACTURED SHOWER PANS WITH SQUARE CORNERS

Fits all TILE SHOWERS and manufactured SHOWER PANS: Acrylic, Gel coat, Vikrel, Solid Surface, Cultured Marble

Important considerations before you begin: The installation of horizontal end caps is highly recommended for proper fit and finish at corners. The caps will provide proper fit and finish to the where the dam meets the side walls. Finished caps also prevent water from being trapped in the dam itself or exiting the shower area insuring a lasting easy to maintain water seal. A properly sized curtain with heavy tape weights combined with a water retainer is the most complete and effective system available today.

ORDER THE CORRECT LENGTH

Make sure you have ordered the correct length. See chart below. The water retainer strip is designed to travel along the floor to the wall radius until vertical, then capped.

SIZE VERIFICATION CHART FOR ALL FACTORY MANUFACTURED SHOWER UNITS

SIZE SHOWER & PART NUMBER

36" ADA barrier free (36" I.D. opening)

42CWR-White

48" barrier free (45-46" I.D opening)

54CWR-White

60" ADA barrier free shower (60" I.D. opening)

66CWR-White

Finished Square End Cap (pair required)

EX1614-White

NOTE: 1 1/2" wide flat mounting surface required.

INSTALLATION STEPS WITH SQUARE END CAPS

1. Thoroughly clean threshold surface of all soap scum and debris using standard bath cleanser. Chemically clean surface with rubbing alcohol.
2. Dry Fit: measure the required length. Be sure to include inserted end caps in overall measurement.
3. Trim Caps on backside wall & floor mating surfaces if necessary to the contour of the corner for tight fit and finish to minimize caulking.
4. Determine and mark center point of shower.
5. Determine and mark center point of water retainer strip.
6. Turn over water retainer strip and make cut on orange peel off strip at half way mark. Peel off a portion (approx. 4") of the orange peel off strip in one direction exposing the adhesive.
7. Align strip with pre-determined half way mark.
8. Press on and adhere approximately 4" of strip.
9. Pull and stretch to wall and align before removing remainder of orange peel off strip.
10. Press into place.
11. Peel, stretch, alien and pull remaining half to wall. Press into place.



Collapsible Continued

by ella's bubbles

12. Dry fit end caps to insure proper fit. (Trim length if required after stretching & adhering dam)
13. Once proper fit is verified, prepare to apply silicone adhesive caulking.
14. Apply quality silicone adhesive caulking to floor, side wall and male insert end of cap. Push in the male end of your end cap into the water retainer.
15. Wipe clean with rubbing alcohol.
16. Allow 12 hours until adhesive cures before use.
17. Tile Application Grout Line joints: The grout joints or entire outer edge beneath the retainer must be caulked to prevent soap and shower debris from lodging beneath the retainer. The adhesive tape does not extend to the edge (by design) to allow the retainer to absorb the impact energy of a rolling shower chair in high use applications. Wipe off excess caulk and let cure (according to caulk specifications) prior to shower use.

© 2013, The Praxis Companies, LLC
435 Industrial Rd., Savannah, TN 38372
Customer Service: 800.443.7269
www.praxiscompanies.com



Ella Accessible Shower In A Box Warranty Information

For all customers of private labels who complete the Ella's Bubbles Product Registration Form and return the same to the Ella's Bubbles Corporate Office, Ella's Bubbles will use its best efforts to facilitate any customer warranty claim. Accordingly for any warranty claim brought to Ella's Bubbles, terms and provisions written under the original manufacturer warranty shall to the extent reasonably possible be managed through Ella's Bubbles to provide direct support and service to the consumer. The original manufacturer's warranty is stated below:

Units manufactured of fiberglass reinforced polyester resin, that it will, free of charge, repair any Ella's unit found to be defective in material or workmanship upon inspection by an authorized representative of Ella's for a period of thirty (30) years from the date of purchase of the unit by a qualified professional. The exchange of a unit is limited to supplying a replacement unit of comparable size and style and does not include any cost of removal or installation. Any component part supplied by Ella's carries the same limited warranty provided by our supplier for a period of one (1) year. Any Ella's product will carry a thirty (30) year limited warranty against manufacturing defects. This warranty shall be voided if the unit is moved from its place of initial installation or is not installed in accordance with the instructions supplied by the manufacturer of the unit. Further, this warranty does not apply if the unit has been subjected to accident, abuse, misuse, damage caused by flood, fire, or act of God. The owner agrees by use of the unit that the obligations of Ella's Bubbles, LLC. shall not exceed to contingent or indirect damage or injury to the structure of its contents, that the obligations of Ella Walk in Baths are limited to those set forth herein, and that no other obligations, expressed or implied, are assumed by Ella's Bubbles.

All mailing notification must be sent via certified mail to:

Ella's Bubbles, LLC.
2101 S. Carpenter Street
Chicago, IL 60608
Email: info@ellasbubbles.com

Model: _____ Serial Number: _____

Purchase Date: _____ Purchase Price: _____

Place of Purchase: _____

Contact Name: _____ Phone Number: _____

Upon completing the installation of an Ella Walk In Bath, the following Warranty Activation Form must be completed, signed by both the customer and installer, and returned to Ella's Bubbles, LLC. In order for the Warranty to be activated (faxed, scanned, or emailed, or hard copy mailed).

To be initialed by the installer(s) _____

- ___ At the time of delivery, all products were inspected thoroughly and any damage to crates, boxes, or cartons was noted on the appropriate paperwork.
- ___ Shower floor is level and has been installed with the proper adhesive or mortar compound in accordance to the manufacturer's specifications. As mortar/adhesive sets up, make sure the proper drain slope has been maintained. Base should slope towards drain in all directions (test by using a 2 foot level from the drain to all adjacent walls)
- ___ All cure times for bonding/sealing agents have been properly observed and the customer has been clearly notified and instructed to obey such guidelines before using the product.
- ___ Shower drain is installed properly and has been tested to ensure that it is free of defect and does not leak.
- ___ Shower walls are lined up properly and there is a uniform gap of no more than 1/8" between each section that has been sealed with 100% silicone. Silicone beads are consistent and have been inspected and are free of any pin holes or debris that may cause leaks.
- ___ Shower valve and all plumbing components have been pressure tested and are functioning properly without any leaks.
- ___ All accessories which may be mounted to the shower walls (including shower seats, grab bars, soap dishes, shower mounts...etc) have been anchored properly and installed in accordance with the manufacturer's instructions and additional bracing has been added if weight limits are exceeded.

OWNER'S INFORMATION:

Name

Address

City

State

ZIP

Telephone

E-mail

Date

Signature

INSTALLER'S INFORMATION:

Company Name

Installer's Name

Address

City

State

ZIP

Telephone

E-mail

Date

Signature

Copy of sales receipt must be included
with warranty activation forms.

To activate manufacturer's warranty please complete both pages and use one of the options below to submit.

Via mail: Ella's Bubbles, LLC.
Warranty Department
2101 S. Carpenter St. Chicago, IL60608

Via fax: 1-312-666-3551

Via email: warranty@ellasbubbles.com